

# SPIRAL MIXER FITTED WITH HOIST

**MODEL: CG/450KG-ST**

One of the many advantages of the spiral mixer is the superior oxygenation of dough. By ideally positioning the Separation Bar and Spiral Arm, our mixer achieves optimally oxygenated dough while processing gently enough to maintain the integrity of the yeast. The result is increased volume and minimal increase of dough temperature.

The CG/450KG-ST Spiral Mixer economically processes 993 pounds of finished dough — a quantity once limited to other types of mixers.

The CG/450KG-ST can be configured as a standard Two Speed model fitted upon a hoist, or with a Programmable Logic Control (PLC) drive system with variable speed capability. Set at a low height the Hoist deposits dough into a trough or onto a table. It can also be set higher to deposit dough directly into another machine for further processing.

The flexibility of the PLC Drive System makes it possible to program the unit for various mixing needs. With optional software and hardware, the unit can be programmed to stop the mixing process at a certain dough temperature. More detailed programming is also available, such as specific RPMs for different types of dough. The ability to program many different RPMs and mixing times for various dough recipe's makes this spiral mixer easy to use in the bakery. Simply call up the program and initiate the work cycle via the panel. Our automated system results in precise mixing and high productivity.

Short of a manual probe in the dough, the optional temperature sensor is the most accurate method of measuring dough temperature. The digital screen on the operator's panel is configured in Celsius or Fahrenheit.

The CG/450KG-ST Spiral Mixer was built to process high gluten content dough for prolonged periods. The mixer features a stainless steel bowl, separation bar, and spiral arm. All components are top quality and CSA approved and/or UL Listed. Larger models available upon request. Please inquire.



**CINELLI**  
**ESPERIA**  
CORPORATION

Our Goal is Simple...  
To Help You Reach Yours

Manufacturers of  
Quality Bakery Machinery  
Since 1972.



**CG/450KG-ST**

G. CINELLI-ESPERIA CORPORATION®, the standard by which all will be judged

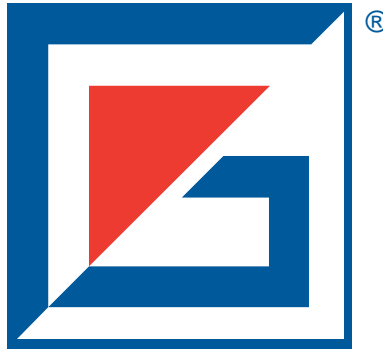

**TECHNICAL DATA**  
**SPIRAL MIXER FITTED WITH HOIST** **MODEL: CG/450KG-ST**

		<b>METRIC</b>		<b>IMPERIAL</b>
Dimensions	[cm]	264 x 224 x 201	[in]	104" x 88" x 79"
Installed Power	[kW]	33	[HP]	43
Total Amperage	[Amps]	90 @ 460-3-50/60*		
Flour Capacity	[kg]	300	[lb.]	661
Dough Capacity	[kg]	450**	[lb.]	991**
Weight	[kg]	3,337	[lb.]	7,350
Shipping Weight	[kg]	3,519	[lb.]	7,750
Shipping Volume	[m3]	12	[cu.ft.]	543

\* Offered in this electrical configuration only; 460Volt, 3 Phase, either 50 or 60 Hertz.  
 \*\* Based upon no less than 50% moisture content within total specified capacity

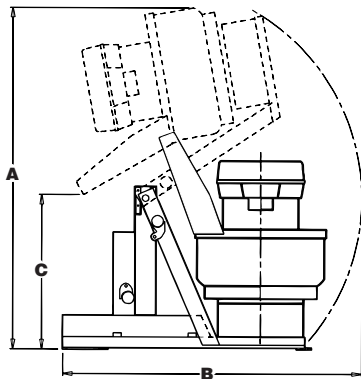

<b>MIXER 450kg. HOIST OPTION DIMENSIONS</b>		
A	330 cm	130"
B	292 cm	115"
C	147 cm	58"
D	224 cm	88"
E	264 cm	104"

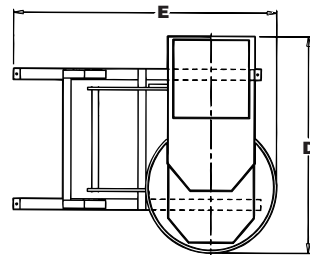

DIMENSIONS = (L x H x H)



ALL DATA NOT BINDING. G. CINELLI - ESPERIA CORPORATION® RESERVES THE RIGHT TO EFFECT MODIFICATIONS WITHOUT PRIOR NOTIFICATION.

**CINELLI**  
**ESPERIA**  
 CORPORATION

380 Chrislea Road,  
 Woodbridge, Ontario  
 L4L 8A8 Canada

Tel: (905) 856-1820; 850-1800  
 Fax: (905) 850-2989

Web Site: [www.gcinelli-esperia.com](http://www.gcinelli-esperia.com)

Printed in Canada

® DESIGNATED TRADEMARK REGISTERED IN  
 CANADA, USA, MEXICO & RUSSIA  
 OWNED BY G. CINELLI - ESPERIA CORPORATION