

HOIST OPTION

MODELS: ST

The hoist option was designed to be used as an indispensable tool for high output operations, or for baking operations that seek to improve efficiency. With the hoist, you are able to discharge mixed dough from your mixer onto a work table or directly into the hopper of a machine such as a Bread Divider.

The hoist is designed to withstand countless hoist operations without frame distortion. The frame was specifically reinforced to cope with payloads much heavier than the hoist will ever lift. The forks and feet of the hoist were designed to maintain stability and an evenly distributed center of gravity completely through the lifting cycle. Dual hydraulic pistons were implemented on larger models to aid balance, effective lifting, reduce frame flex, distortion, and to prevent load shifting during the lift cycle.

Every facet of the unstable nature of such a device was a major consideration, hence the design reduces concerns of safety and longevity of the hoist.



Made with pride
in Canada



G. Cinelli-Esperia Corporation, the standard by which all will be judged



TECHNICAL DATA
HOIST OPTION

MODELS ST-H

	CG/160ST	CG/200ST	CG/250ST	CG/300ST
H INTO DIVIDER	66in./168cm	66in./168cm	66in./168cm	66in./168cm
L ON TABLE	52in./132cm	52in./132cm	52in./132cm	52in./132cm
A TOTAL HEIGHT	106in./267cm.	106in./267cm	112in./285cm	112in./285cm
B TOTAL WIDTH	77in./195.6cm	77in./195.6cm	85in./216cm	85in./216cm

** When ordering, please specify Low or High Deposit, and Left or Right Deposit. **

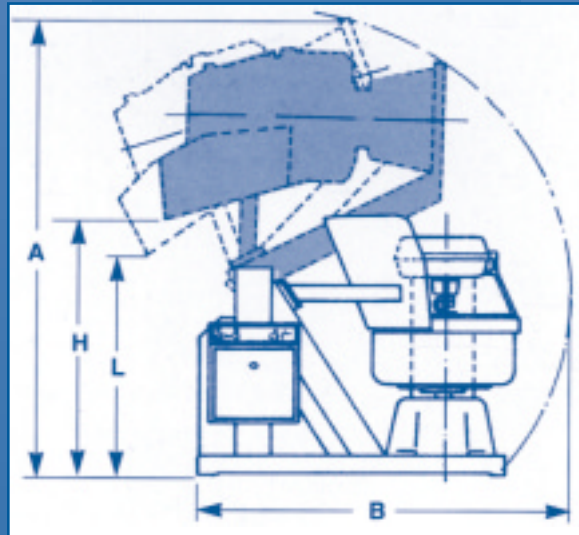

CINELLI
ESPERIA
CORPORATION

380 Chrislea Road,
Woodbridge, Ontario
L4L 8A8 Canada

Tel: (905) 856-1820; 850-1800
Fax: (905) 850-2989

www.gcinelli-esperia.com

© DESIGNATED TRADEMARK REGISTERED IN
CANADA, USA & MEXICO.
OWNED BY G. CINELLI - ESPERIA CORPORATION